

NPN/PNP EPITAXIAL SILICON TRANSISTORS

PNP CSA1381
NPN CSC3503



TO-126

TO-126
Plastic Package
RoHS compliant

APPLICATION:

1. Audio, Voltage Amplifier and Current Source
2. CRT Display, Video Output
3. General Purpose Amplifier

ABSOLUTE MAXIMUM RATINGS (Ta = 25 °C Unless otherwise specified)

PARAMETER		SYMBOL	VALUE	UNIT
Collector - Base Voltage		B_{VCBO}	300	V
Collector - Emitter Voltage		B_{VCEO}	300	V
Emitter - Base Voltage		B_{VEBO}	5.0	V
Collector Current (DC)		I_C	100.0	mA
Collector Current (Pulse)		I_{CP}	200.0	mA
Total Device Dissipation	$T_C=25^{\circ}C$	P_C	7	W
	$T_C=125^{\circ}C$		1.2	
Junction and Storage Temperature		T_J, T_{STG}	-55 to +150	°C

THERMAL CHARACTERISTICS ¹

Thermal Resistance, Junction to Case	$R_{\theta JC}$	17.8	°C/W
--------------------------------------	-----------------	------	------

Note:-

For PNP type voltage and current values are negative.



Continental Device India Pvt. Limited

An IATF 16949, ISO9001 and ISO 14001 Certified Company



ELECTRICAL CHARACTERISTICS ($T_C = 25^\circ\text{C}$ unless otherwise noted)

PARAMETER	SYMBOL	TEST CONDITION	VALUE			UNIT
			MIN	TYP	MAX	
Collector-Base Breakdown Voltage	B_{VCBO}	$I_C = -10\mu\text{A}, I_E = 0$	300	--	--	V
Collector-Emitter Breakdown Voltage	B_{VCEO}	$I_C = -1\text{mA}, I_B = 0$	300	--	--	V
Emitter-Base Breakdown Voltage	B_{VEBO}	$I_E = -10\mu\text{A}, I_C = 0$	5	--	--	V
Collector Cut-off Current	I_{CBO}	$V_{CB} = -200\text{V}, I_E = 0$	--	--	0.1	μA
Emitter Cut-off Current	I_{EBO}	$V_{EB} = -4\text{V}, I_C = 0$	--	--	0.1	μA
DC Current Gain	h_{FE}^2	$V_{CE} = -10\text{V}, I_C = -10\text{mA}$	40	--	320	
Collector-Emitter Saturation Voltage	$V_{CE(sat)}$	$I_C = -20\text{mA}, I_B = -2\text{mA}$	--	--	0.6	V
Base-Emitter Saturation Voltage	$V_{BE(sat)}$	$I_C = -20\text{mA}, I_B = -2\text{mA}$	--	--	1	V
Current Gain Bandwidth Product	f_T	$V_{CE} = -30\text{V}, I_C = -10\text{mA}$	--	150	--	MHz
Output Capacitance	C_{ob}	$V_{CB} = -30\text{V}, f = 1\text{MHz}$	--	3.1	--	pF
Reverse Transfer Capacitance	C_{re}	$V_{CB} = -30\text{V}, f = 1\text{MHz}$	--	2.3	--	pF

Note:

1. Device mounted on minimum pad size
2. h_{FE} CLASSIFICATION

CLASSIFICATION	C	D	E	F
h_{FE}	40 ~ 80	60 ~ 120	100 ~ 200	160 ~ 320

TYPICAL CHARACTERISTICS CURVES

Fig 1: Static Characteristics

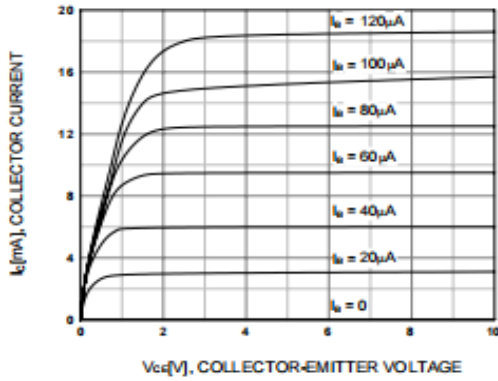

Fig 4: Static Characteristics

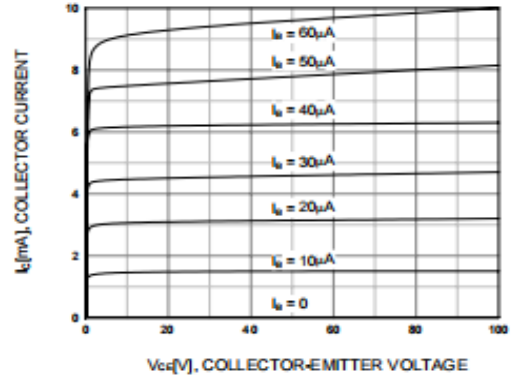

Fig 2: DC Current Gain

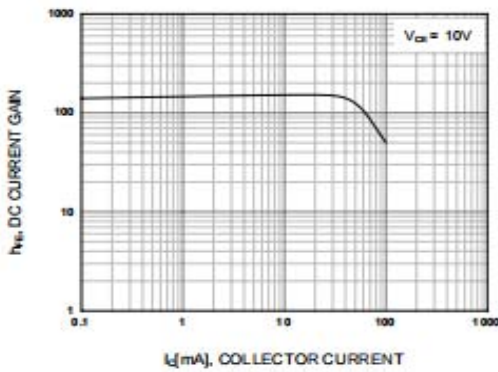

Fig 5: Base-Emitter Saturation Voltage
 Collector-Emitter Saturation Voltage

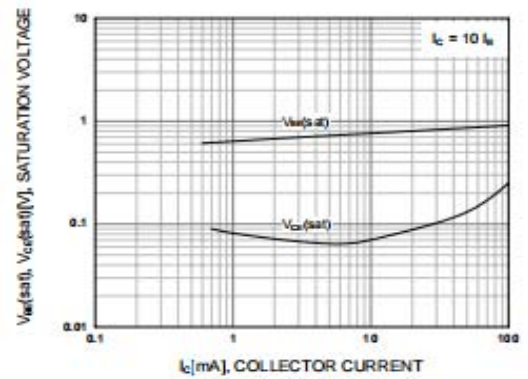

Fig 3: Base-Emitter On Voltage

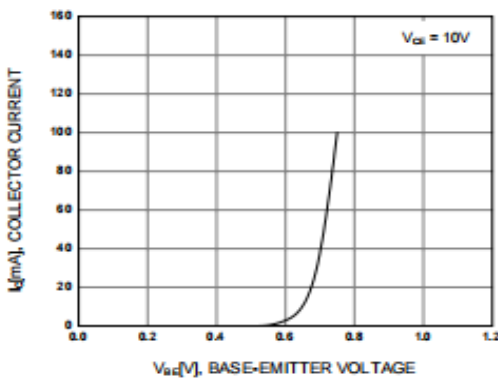
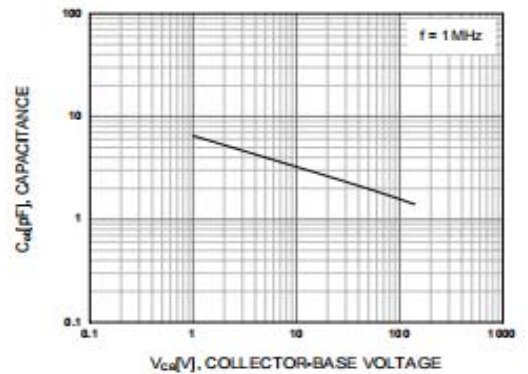

Fig 6: Collector Output Capacitance



TYPICAL CHARACTERISTICS CURVES

Fig 7: Reverse Transfer Capacitance

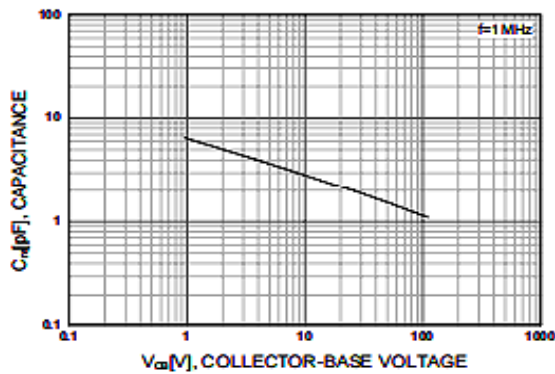

Fig 8: Safe Operating Area

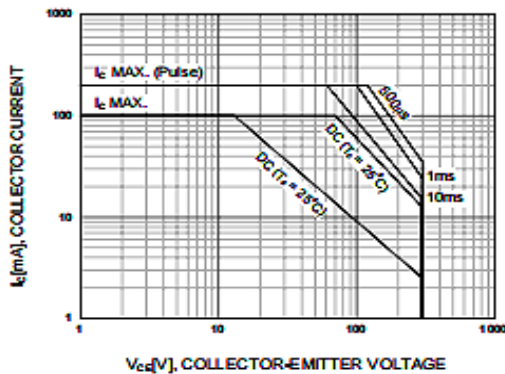

Fig 9: Current Gain Bandwidth Product

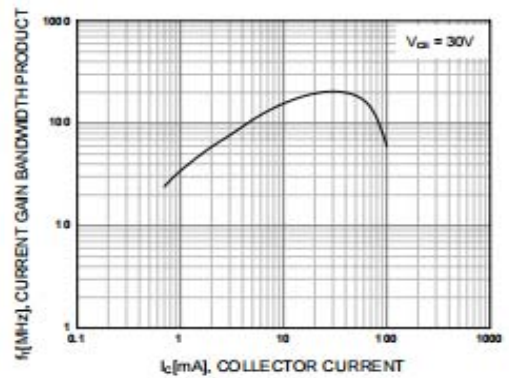
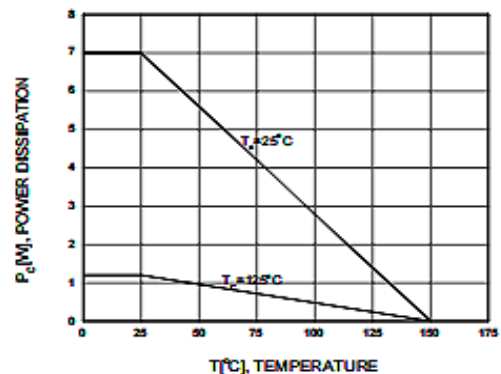
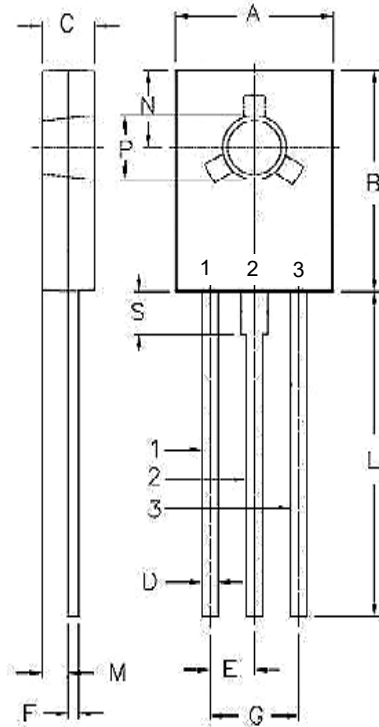

Fig 10: Power Derating



PACKAGE DETAILS

TO-126 Leaded Plastic package



DIM	MIN	TYP.	MAX
A	7.4	--	7.8
B	10.5	--	10.8
C	2.4	--	2.7
D	0.64	--	0.88
E	--	2.25 TYP.	--
F	0.39	--	0.63
G	--	4.5	--
L	--	15.7	--
M	--	1.27	--
N	--	3.75	--
P	2.9	--	3.2
S	--	2.5	--

All dimensions are in mm

PIN CONFIGURATION

1. EMITTER
2. COLLECTOR
3. BASE

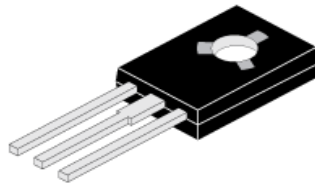



Recommended Product Storage Environment for Discrete Semiconductor Devices

This storage environment assumes that the Diodes and transistors are packed properly inside the original packing supplied by CDIL.

- Temperature 5 °C to 30 °C
- Humidity between 40 to 70 %RH
- Air should be clean.
- Avoid harmful gas or dust.
- Avoid outdoor exposure or storage in areas subject to rain or water spraying .
- Avoid storage in areas subject to corrosive gas or dust. Product shall not be stored in areas exposed to direct sunlight.
- Avoid rapid change of temperature.
- Avoid condensation.
- Mechanical stress such as vibration and impact shall be avoided.
- The product shall not be placed directly on the floor.
- The product shall be stored on a plane area. They should not be turned upside down. They should not be placed against the wall.

Shelf Life of CDIL Products

The shelf life of products is the period from product manufacture to shipment to customers. The product can be unconditionally shipped within this period. The period is defined as 2 years.

If products are stored longer than the shelf life of 2 years the products shall be subjected to quality check as per CDIL quality procedure.

The products are further warranted for another one year after the date of shipment subject to the above conditions in CDIL original packing.

Floor Life of CDIL Products and MSL Level

When the products are opened from the original packing, the floor life will start.

For this, the following JEDEC table may be referred:

JEDEC MSL Level		
Level	Time	Condition
1	Unlimited	≤30 °C / 85% RH
2	1 Year	≤30 °C / 60% RH
2a	4 Weeks	≤30 °C / 60% RH
3	168 Hours	≤30 °C / 60% RH
4	72 Hours	≤30 °C / 60% RH
5	48 Hours	≤30 °C / 60% RH
5a	24 Hours	≤30 °C / 60% RH
6	Time on Label(TOL)	≤30 °C / 60% RH



Continental Device India Pvt. Limited

An IATF 16949, ISO9001 and ISO 14001 Certified Company

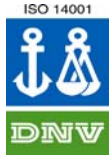

Customer Notes

Component Disposal Instructions

1. CDIL Semiconductor Devices are RoHS compliant, customers are requested to please dispose as per prevailing Environmental Legislation of their Country.
2. In Europe, please dispose as per EU Directive 2002/96/EC on Waste Electrical and Electronic Equipment (WEEE).

Disclaimer

The product information and the selection guides facilitate selection of the CDIL's Semiconductor Device(s) best suited for application in your product(s) as per your requirement. It is recommended that you completely review our Data Sheet(s) so as to confirm that the Device(s) meet functionality parameters for your application. The information furnished in the Data Sheet and on the CDIL Web Site/CD are believed to be accurate and reliable. CDIL however, does not assume responsibility for inaccuracies or incomplete information. Furthermore, CDIL does not assume liability whatsoever, arising out of the application or use of any CDIL product; neither does it convey any license under its patent rights nor rights of others. These products are not designed for use in life saving/support appliances or systems. CDIL customers selling these products (either as individual Semiconductor Devices or incorporated in their end products), in any life saving/support appliances or systems or applications do so at their own risk and CDIL will not be responsible for any damages resulting from such sale(s).

CDIL strives for continuous improvement and reserves the right to change the specifications of its products without prior notice.



CDIL is a registered trademark of

Continental Device India Pvt. Limited

C-120 Naraina Industrial Area, New Delhi 110 028, India.

Telephone +91-11-2579 6150, 4141 1112 Fax +91-11-2579 5290, 4141 1119

email@cdil.com www.cdil.com

CIN No. U32109DL1964PTC004291